

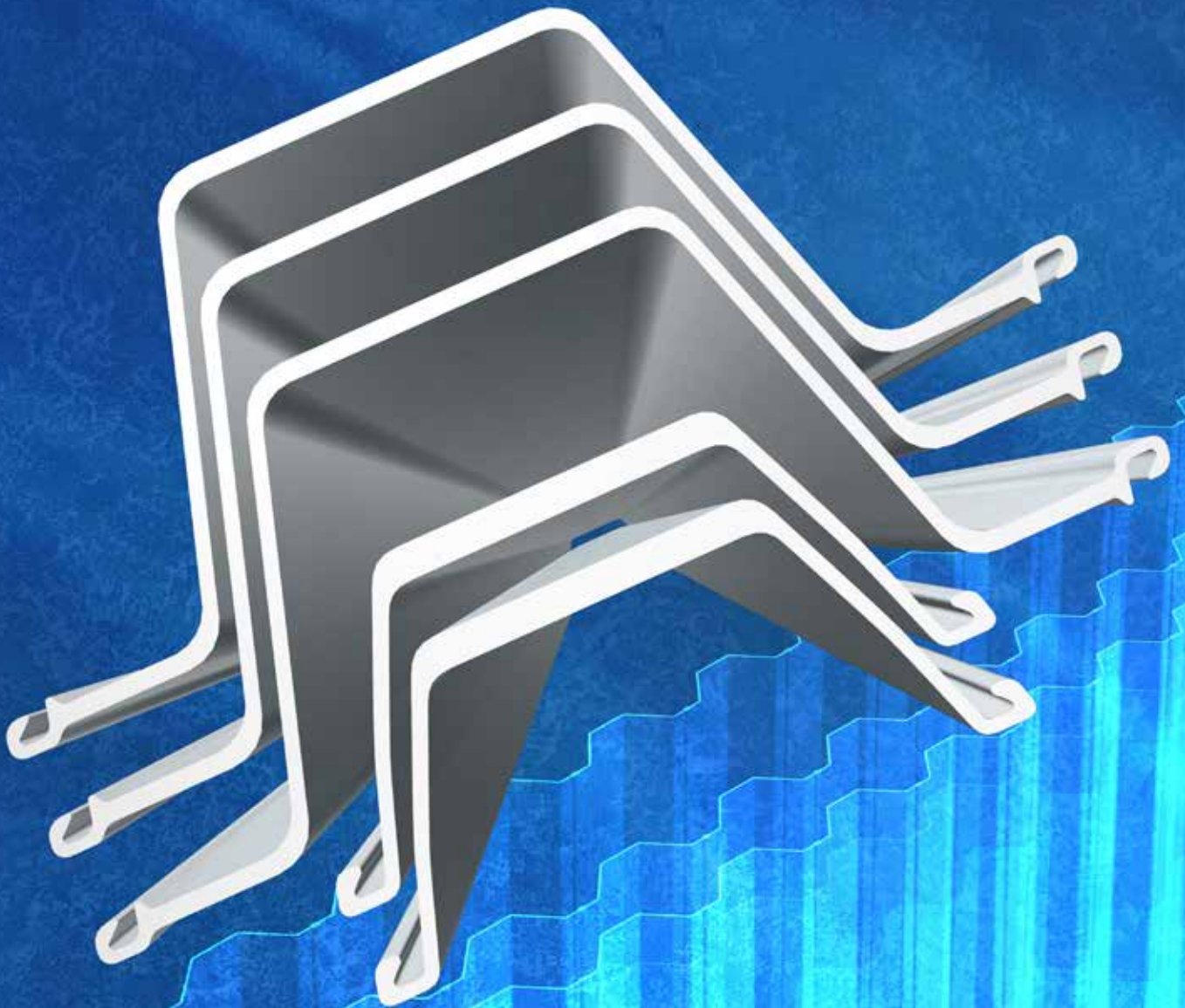

JFE

JFESP™

JFE Steel Sheet Piles



JFE スチール 株式会社

INTRODUCTION

Steel sheet piles that are widely used in the construction of river embankments, quay walls of ports, retaining walls, cut-off walls, earthquake strengthening structures, and in many other types of construction work are becoming increasingly important.

JFE has been taking full advantage of the state-of-the-art rolling mills at West Japan Works to produce steel sheet piles (U-shaped and Hat-shaped) that conform to the new JIS standard (JIS A 5523) established in 2000 and to conventional JIS standards (JIS A 5528). We also pride ourselves on the construction of corner steel sheet piles made by integral roll forming and heavy-duty-coated steel sheet piles (JFE Marine Coat™) for use in the marine environment. We are confident that the wide range of steel sheet piles produced by JFE (JFESP™) will fully satisfy the demanding needs of our customers.

You are kindly invited to find out for yourself the many advantages to be had in using our JFESP™ steel sheet piles, as well.



◀ West Japan Works (Fukuyama)

▼ West Japan Works (Kurashiki)

CONTENTS

■ Features and Characteristics	1
■ Usage and Applications	1
■ Production Process of Steel Sheet Piles	2
■ Standards	4
■ Shape and Cross-sectional Performance	6
■ Interchangeability and Turning Angle of Steel Sheet Piles ...	11
■ Corner Steel Sheet Piles	12
■ Deformed Steel Sheet Piles	13
■ Table of Weights	14
■ JFESP™-Related Products	
H-Shaped Steel Piles	15
JFE Marine Coat™ Steel Sheet Piles	16
(Heavy-duty Corrosion-proof Steel Sheet Piles)	
■ Section Modulus of Steel Sheet Piles after Corrosion	18
■ Construction Methods	20
■ Examples of Labeling	21



Features and Characteristics

1 A wide range of types and cost efficiencies to meet every need

Steel sheet piles (U-shaped and Hat-shaped) are available for economical design.

2 High reliability

Steel sheet piles are produced using the state-of-the-art facilities at our West Japan Works under rigorous quality control.

3 Excellent workability

The joints of steel sheet piles have a sufficient margin of flexibility when combined together to ensure excellent interchangeability and workability.



Usage and Applications

Steel sheet piles can be used for a very wide range of purposes including those listed below.

- 1 For permanent structures** — Quay walls, embankments, breakwaters, retaining walls, scour protection walls, cut-off walls, dams, and training dikes, amongst others
- 2 For temporary works** — Earth retaining, breasting, double cofferdams, and islet building, amongst others
- 3 Special uses** — Oil retaining walls, protection of underground oil transport pipes, fill-up aseismic reinforcement walls, liquefaction prevention, and land subsidence prevention, amongst others

Production Process of Steel Sheet Piles

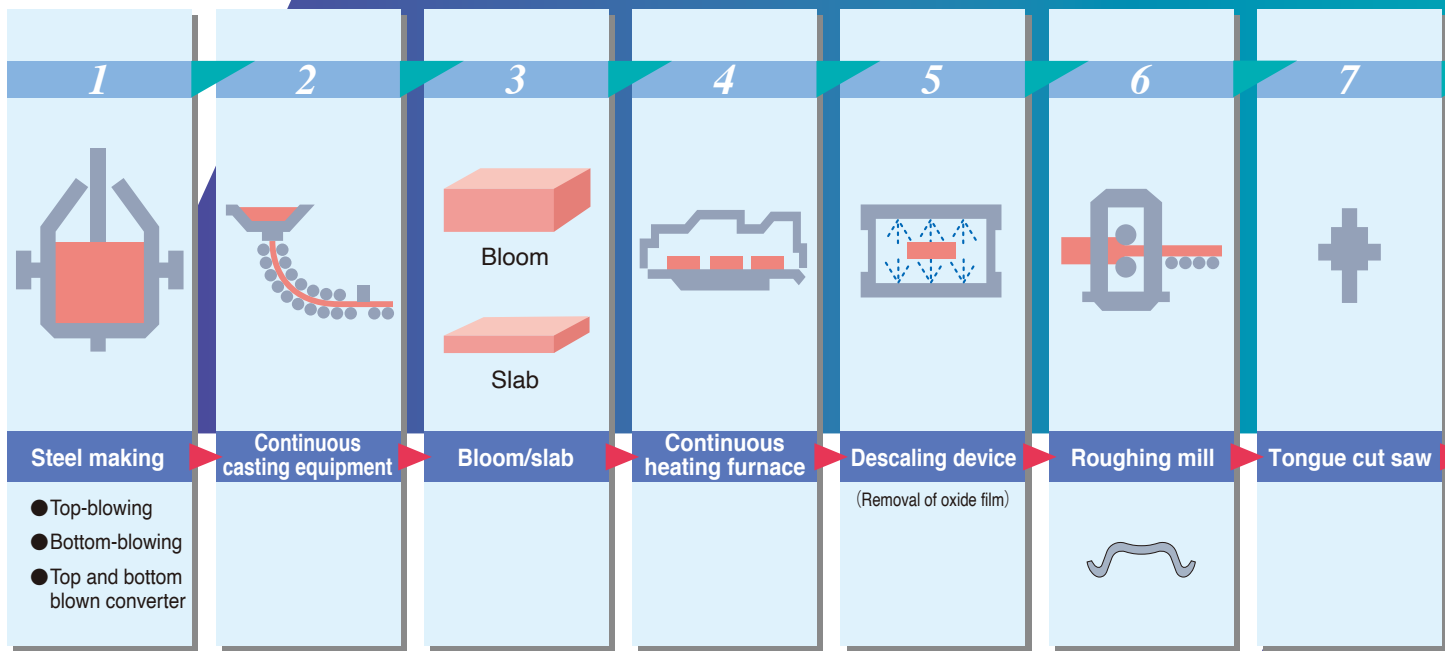

Intermediate rolling mill



Hot saw



Cooling bed

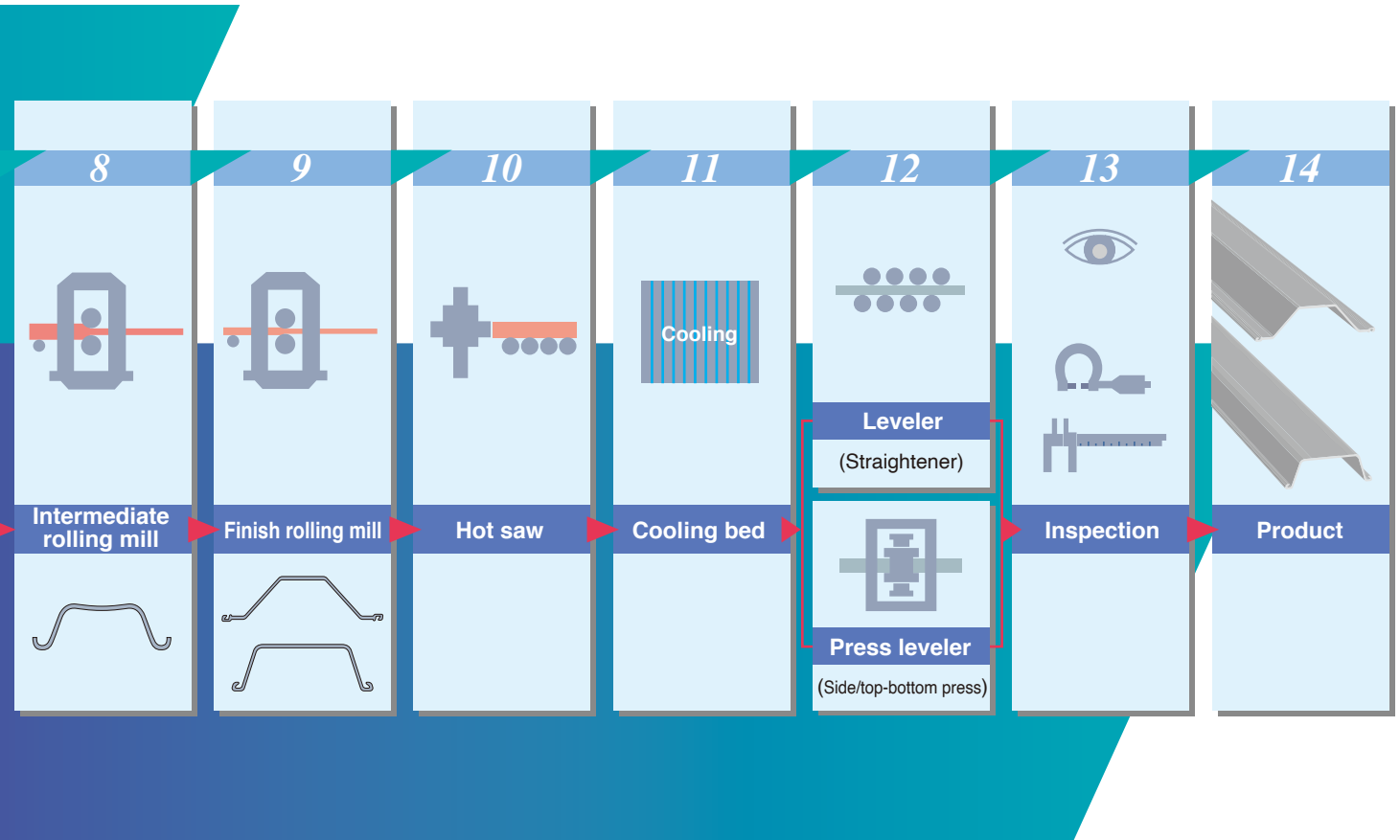
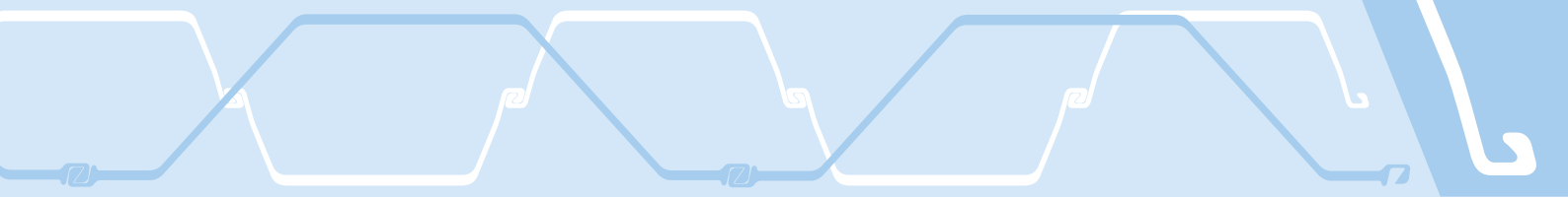

Leveler



Inspection of products

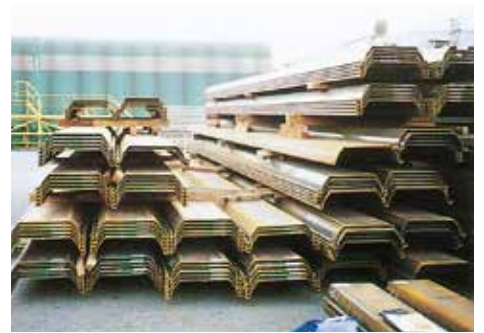

Shipment of products

Standards

The standards most affecting the production of steel sheet piles are JIS A 5523 (hot-rolled steel sheet piles for welding) and JIS A 5528 (hot-rolled steel sheet piles).

Hat-shaped Steel Sheet Piles

Chemical composition

(Unit: %)

Standard	Designation	C	Si	Mn	P	S	Free nitrogen	Ceq
JIS A 5523 (hot-rolled steel sheet piles for welding)	SYW295	0.18 max.	0.55 max.	1.50 max.	0.040 max.	0.040 max.	0.0060 max.	0.44 max.
	SYW390 [*]	0.18 max.	0.55 max.	1.50 max.	0.040 max.	0.040 max.	0.0060 max.	0.45 max.

* SYW390 is not manufactured usually, If you want this products, contact with us beforehand.

Notes:1. The carbon equivalent is calculated using the following formula: Carbon equivalent (%) = C + Mn/6 + Si/24 + Ni/40 + Cr/5 + Mo/4 + V/14
2. The value of free nitrogen is represented by the total nitrogen in accordance with JIS A 5523, item #5. Chemical composition, Note 2.

Mechanical properties

Standard	Designation	Yield point or yield strength (N/mm ²)	Tensile strength (N/mm ²)	Test piece	Elongation (%)	Charpy absorbed energy (J) Height of sample x Width (mm)		
						10 x 10	10 x 7.5	10 x 5
JIS A 5523 (hot-rolled steel sheet piles for welding)	SYW295	295 min.	450 min.	1A	18 min.	43 min.	32 min.	22 min.
				14B	24 min.			
	SYW390 [*]	390 min.	490 min.	1A	16 min.	43 min.	32 min.	22 min.
				14B	20 min.			

* SYW390 is not manufactured usually, If you want this products, contact with us beforehand.

Notes: The Charpy absorbed energy is the value at the test temperature of 0°C.

Tolerances for shapes and dimensions

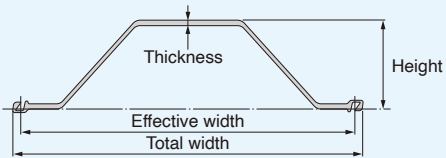
Cross-sectional shape		Hat-shaped Steel Sheet Piles	
			
Item	Total width	+10mm -5mm	
			Difference in total width
	Height	±4%	
Thickness	Under 10mm	±1.0mm	
	10mm and over to 16mm excl.	±1.2mm	
	16mm or over	±1.5mm	
	Length	+ Not specified, 0	
Deflection	10m or under in length	Length(m) x 0.12% max.	
	Over 10m in length	(Length - 10m) x 0.1% + 12mm max.	
Camber	10m or under in length	Length x 0.25% max.	
	Over 10m in length	(Length - 10m) x 0.2% + 25mm max.	
	End Deflection	-	
	Square cutting difference in section	4% of the width max.	
	Joint engagement angle	≥ 4°	

[Remarks] Deflection is defined as being parallel to the sheet pile wall, and camber perpendicular to the sheet pile wall.

U-shaped Steel Sheet Piles

Chemical composition

(Unit: %)

Standard	Designation	C	Si	Mn	P	S	Free nitrogen	Ceq
JIS A 5523 (hot-rolled steel sheet piles for welding)	SYW295	0.18 max.	0.55 max.	1.50 max.	0.040 max.	0.040 max.	0.0060 max.	0.44 max.
	SYW390 *	0.18 max.	0.55 max.	1.50 max.	0.040 max.	0.040 max.	0.0060 max.	0.45 max.
JIS A 5528 (hot-rolled steel sheet piles)	SY295	-	-	-	0.040 max.	0.040 max.	-	-
	SY390	-	-	-	0.040 max.	0.040 max.	-	-

* SYW390 is not manufactured usually, If you want this products, contact with us beforehand.

Notes:1. The carbon equivalent is calculated using the following formula: Carbon equivalent (%) = C + Mn/6 + Si/24 + Ni/40 + Cr/5 + Mo/4 + V/14
2. The value of free nitrogen is represented by the total nitrogen in accordance with JIS A 5523, item #5. Chemical composition, Note 2.

Mechanical properties

Standard	Designation	Yield point or yield strength (N/mm ²)	Tensile strength (N/mm ²)	Test piece	Elongation (%)	Charpy absorbed energy (J) Height of sample x Width (mm)		
						10 x 10	10 x 7.5	10 x 5
JIS A 5523 (hot-rolled steel sheet piles for welding)	SYW295	295 min.	450 min.	1A	18 min.	43 min.	32 min.	22 min.
				14B	24 min.			
	SYW390 *	390 min.	490 min.	1A	16 min.	43 min.	32 min.	22 min.
				14B	20 min.			
JIS A 5528 (hot-rolled steel sheet piles)	SY295	295 min.	450 min.	1A	18 min.	-		
				14B	24 min.			
	SY390	390 min.	490 min.	1A	16 min.	-		
				14B	20 min.			

* SYW390 is not manufactured usually, If you want this products, contact with us beforehand.

Notes: The Charpy absorbed energy is the value at the test temperature of 0°C.

Tolerances for shapes and dimensions

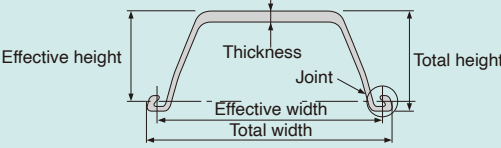
Item		U-shaped steel sheet pile		
				
		Tolerance of JIS A 5523		Tolerance of JIS A 5528
		2, 3, 4, 5L, 6L	2W,3W, 4W	
Total width		Effective width x ±1%	+6mm - 5mm	+10mm - 5mm
Difference in total width		The difference between the max. and min. total widths shall be 4 mm or smaller in the range of 1 m from the end in the longitudinal direction		Not specified
Total height		±4%		±4%
Thickness	Under 10mm	+1.0mm - 0.3mm		±1.0mm
	10mm and over to 16mm excl.	+1.2mm - 0.3mm		±1.2mm
	16mm or over	+1.5mm - 0.3mm		±1.5mm
Length		+ Not specified, 0		+ Not specified, 0
Deflection	10m or under in length	Length x 0.1% max. 20mm max.		Length x 0.12% max.
	Over 10m in length			(Length - 10m) x 0.1% + 12mm max.
Camber	10m or under in length	Length x 0.2% max. 20mm max.		Length x 0.25% max.
	Over 10m in length			(Length - 10m) x 0.2% + 25mm max.
End Deflection		1.5 mm or smaller at 1/2 of the arc-side or tangent-side measurement value 1 m from the end		Not specified
Square cutting difference in section		4% of Effective width max.		4% of width max.
Joint engagement angle		≥6°		Not specified

[Remarks] Deflection is defined as being parallel to the sheet pile wall, and camber perpendicular to the sheet pile wall.

Shape and Cross-sectional Performance

Hat-shaped Steel Sheet Piles

Select an appropriate type of Hat-shaped steel sheet pile based on the usage and load conditions.

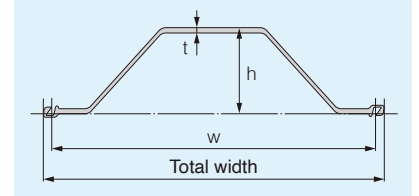

List of cross-sectional performance values

Type	Dimensions			Per steel sheet pile				Per each meter of wall width				
	Effective width W (mm)	Height h (mm)	Thickness t (mm)	Cross section $\times 10^{-4}$ (m ²)	Geometrical moment of inertia $\times 10^{-8}$ (m ⁴)	Section modulus $\times 10^{-6}$ (m ³)	Unit weight (kg/m)	Cross section $\times 10^{-4}$ (m ² /m)	Geometrical moment of inertia $\times 10^{-8}$ (m ⁴ /m)	Section modulus $\times 10^{-6}$ (m ³ /m)	Unit weight (kg/m ²)	Plastic section modulus / Elastic section modulus (Zp/Ze)
JFESP-10H	900	230	10.8	110.0	9,430	812	86.4	122.2	10,500	902	96.0	1.16
JFESP-25H	900	300	13.2	144.4	22,000	1,450	113	160.4	24,400	1,610	126	1.15
JFESP-45H	900	368	15.0	187.0	40,500	2,200	147	207.8	45,000	2,450	163	1.16
JFESP-50H	900	370	17.0	212.7	46,000	2,490	167	236.3	51,100	2,760	186	1.16

Joint efficiency

Since it has a cross-sectional shape where the neutral axis after the wall body construction matches the neutral axis per steel sheet pile, the joint efficiency is 100% regardless of the head constraint.

Conceptual diagram

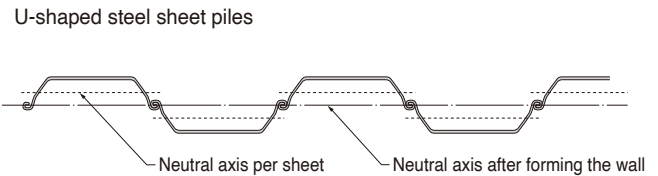
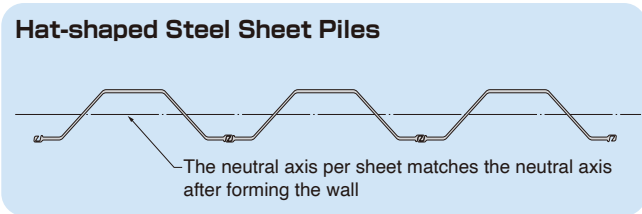

Geometrical moment of inertia and section modulus per weight

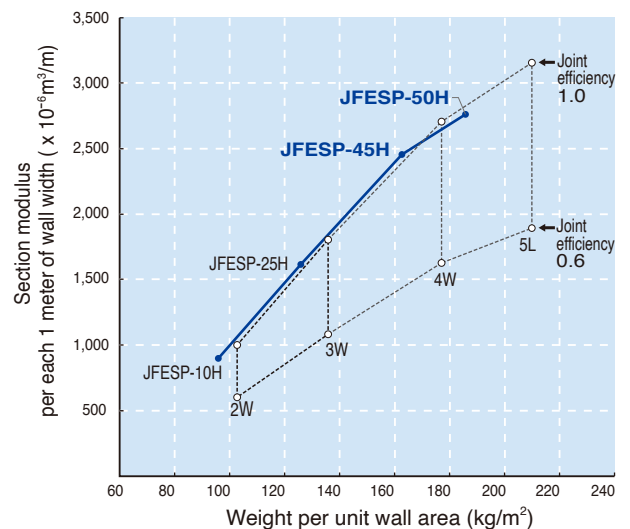
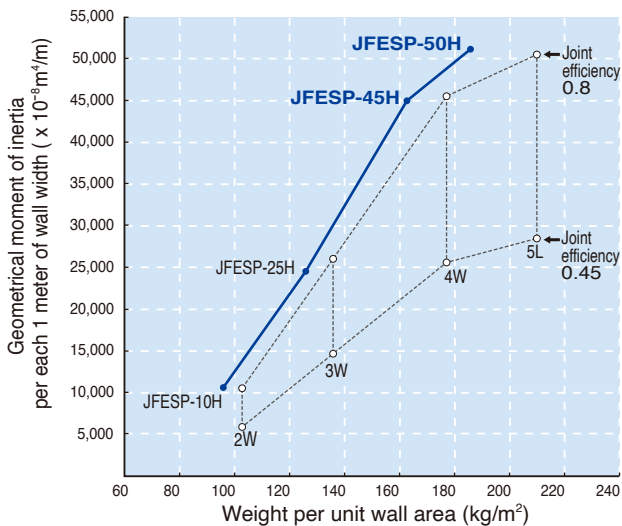

● Features of Hat-shaped Steel Sheet Piles

Excellent workability

● Long length driving is possible

Since it can be placed in a single direction and reduce the penetration resistance due to joint friction, it can be expected to improve the workability in long length driving compared to U-shaped steel sheet piles.

● Space-saving construction is possible

Excellent economic efficiency

● Reduction in the weight of steel materials

Compared to U-shaped steel sheet piles (wide steel sheet piles) with an effective width of 600 mm, it is possible to reduce the weight of steel materials per unit wall area by about 7 to 29%.

● Reduction in construction cost and construction period

With the effective width of 900 mm, the number of sheets used in construction can be reduced to 2/3 compared to wide steel sheet piles.

JFESP-10H

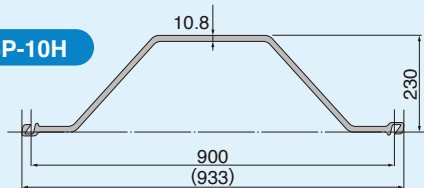

JFESP-45H

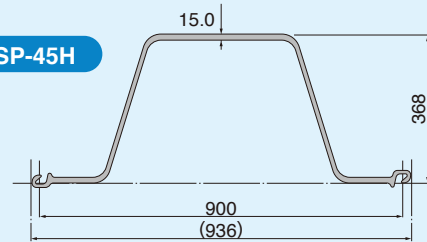

JFESP-25H

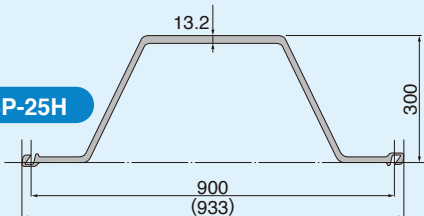

JFESP-50H

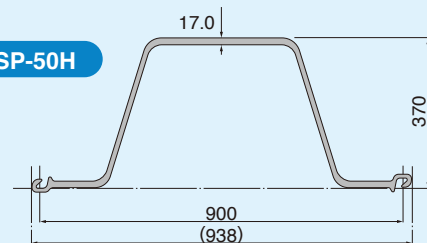

Values in parentheses () indicate internally controlled values. They are subject to change without notice.

Shape and Cross-sectional Performance

U-shaped Steel Sheet Piles

Select an appropriate type of U-shaped steel sheet pile based on the usage and load conditions.

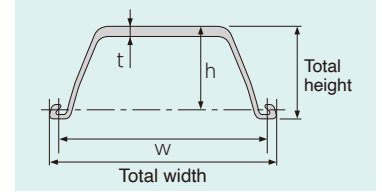

List of cross-sectional performance values

Type	Dimensions			Per steel sheet pile				Per each meter of wall width				
	Effective width W (mm)	Effective height h (mm)	Thickness t (mm)	Cross section $\times 10^{-4}$ (m ²)	Geometrical moment of inertia $\times 10^{-8}$ (m ⁴)	Section modulus $\times 10^{-6}$ (m ³)	Unit weight (kg/m)	Cross section $\times 10^{-4}$ (m ² /m)	Geometrical moment of inertia $\times 10^{-8}$ (m ⁴ /m)	Section modulus $\times 10^{-6}$ (m ³ /m)	Unit weight (kg/m ²)	Plastic section modulus / Elastic section modulus (Zp/Ze)
JFESP-2W	600	130	10.3	78.70	2,110	203	61.8	131.2	13,000	1,000	103	1.13
JFESP-3W	600	180	13.4	103.9	5,220	376	81.6	173.2	32,400	1,800	136	1.14
JFESP-4W	600	210	18.0	135.3	8,630	539	106	225.5	56,700	2,700	177	1.16
JFESP-2	400	100	10.5	61.18	1,240	152	48.0	153.0	8,740	874	120	1.14
JFESP-3	400	125	13.0	76.42	2,220	223	60.0	191.0	16,800	1,340	150	1.13
JFESP-4	400	170	15.5	96.99	4,670	362	76.1	242.5	38,600	2,270	190	1.14
JFESP-5L	500	200	24.3	133.8	7,960	520	105	267.6	63,000	3,150	210	1.16
JFESP-6L	500	225	27.6	153.0	11,400	680	120	306.0	86,000	3,820	240	1.18

Geometrical moment of inertia and section modulus per weight

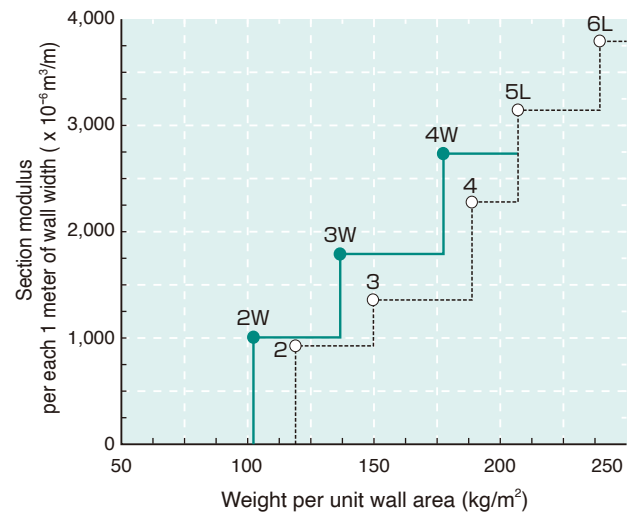
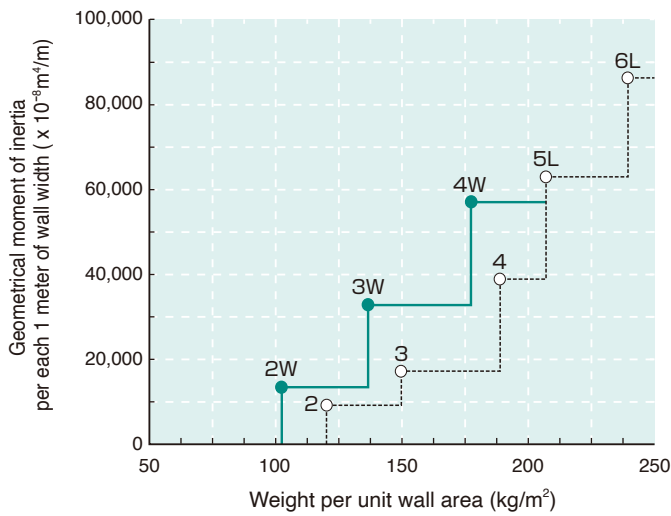

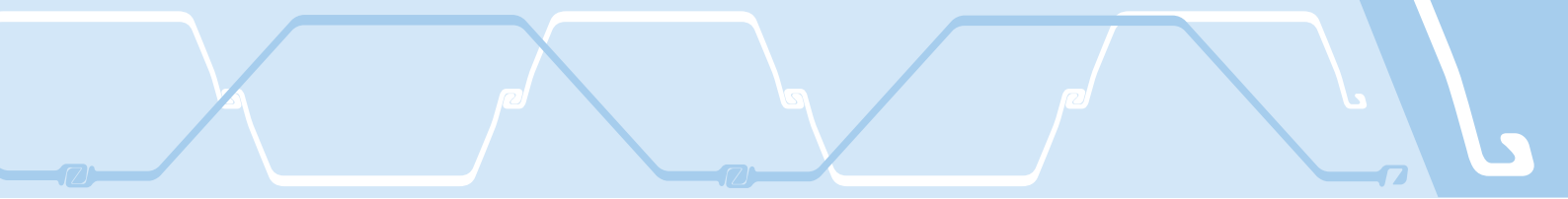

JFESP-2W

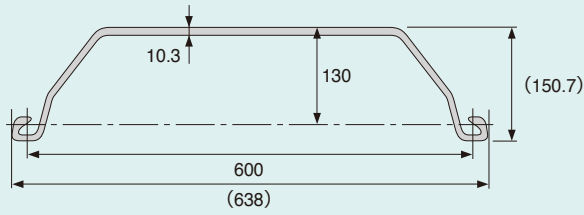

JFESP-2

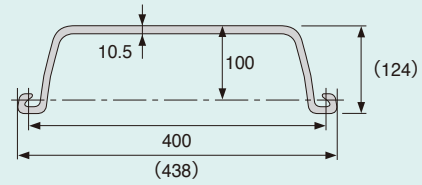

JFESP-3W

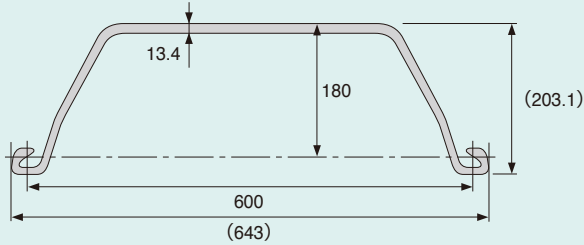

JFESP-3

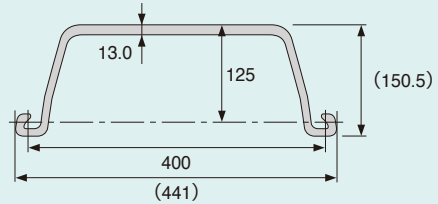

JFESP-4W

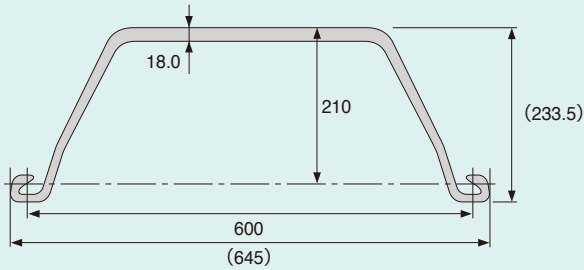

JFESP-4

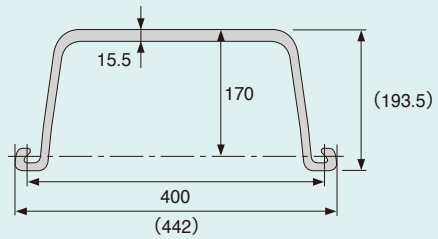

JFESP-5L

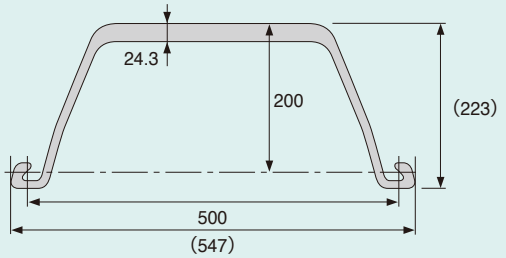

JFESP-6L

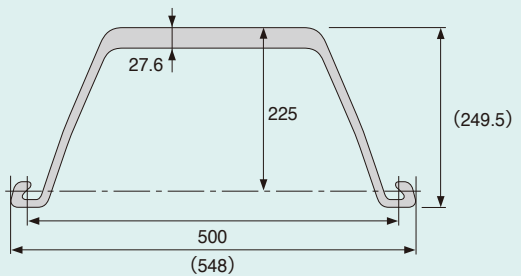

Values in parentheses () indicate internally controlled values. They are subject to change without notice.

Shape and Cross-sectional Performance

Combined Steel Sheet Piles

A combined steel sheet pile is manufactured by welding two U-shaped steel sheet piles. Because of this, it can deliver a large cross-sectional performance, and is ideal for large mooring berths, etc. It is also possible to achieve an economic design suited to design conditions by appropriately combining the models.

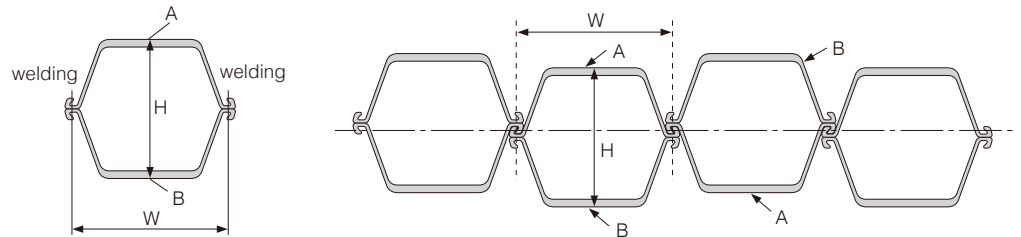

Combined Steel Sheet Piles

Type		Dimensions		Cross section		Geometrical moment of inertia		Section modulus		Weight (kg/m ²)		
A	B	H (mm)	W (mm)	Per steel sheet pile ×10 ⁻⁴ (m ²)	Per each meter of wall width ×10 ⁻⁴ (m ² /m)	Per steel sheet pile ×10 ⁻⁸ (m ⁴)	Per each meter of wall width ×10 ⁻⁸ (m ⁴ /m)	Per steel sheet pile ×10 ⁻⁶ (m ³)	Per each meter of wall width ×10 ⁻⁶ (m ³ /m)	Length of Steel Sheet Pile A / Length of Steel Sheet Pile B		
										100%	90%	80%
JFESP-3W	JFESP-3W	404	600	207.8	346.3	50,600	84,300	2,500	4,170	272	258	245
JFESP-4W	JFESP-3W	435	600	239.2	398.7	66,400	111,000	2,860	4,770	313	299	286
JFESP-4W	JFESP-4W	466	600	270.6	451.0	86,500	144,000	3,710	6,190	354	336	319
JFESP-4	JFESP-4	387	400	194.0	484.0	41,400	103,000	2,140	5,350	380	361	342
JFESP-5L	JFESP-5L	445	500	267.6	535.2	79,000	158,000	3,550	7,100	420	399	378
JFESP-6L	JFESP-5L	471	500	286.8	573.6	92,900	186,000	3,870	7,740	450	429	408
JFESP-6L	JFESP-6L	497	500	306.0	612.0	109,000	217,000	4,370	8,750	480	456	432



Interchangeability and Turning Angle of Steel Sheet Piles

JFESP™ joints can be engaged in the range shown below. However, Hat-shaped steel sheet piles and U-shaped steel sheet piles cannot be engaged.

Hat-shaped Steel Sheet Piles

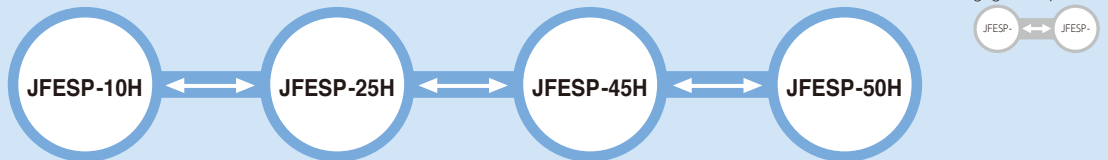

U-shaped Steel Sheet Piles

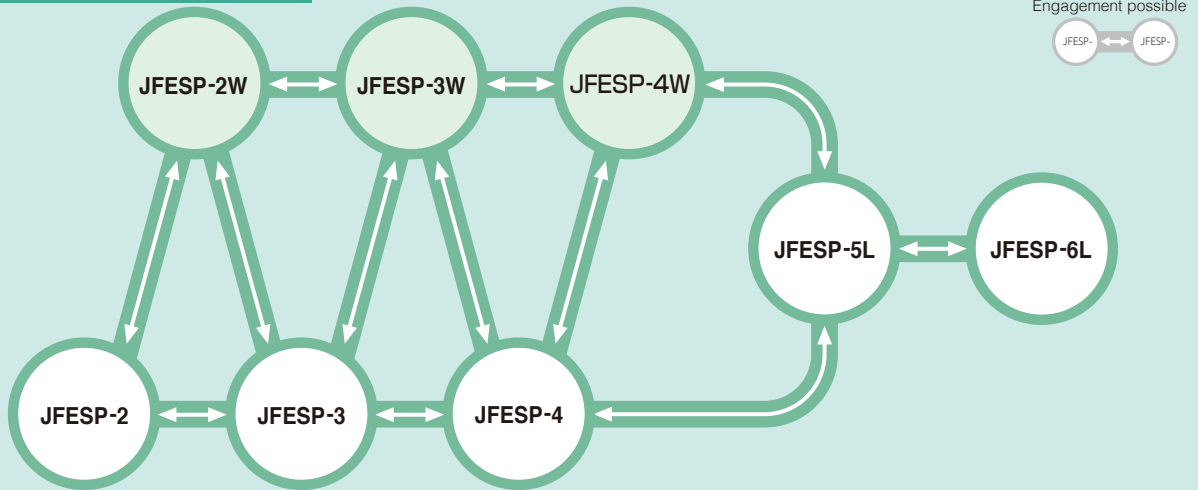

● The standard engagement range is shown here, which may vary according to the construction conditions.

■ Standard rotation angle

The standard rotation angle when steel sheet piles of the same model are engaged is shown below.

Hat-shaped Steel Sheet Piles

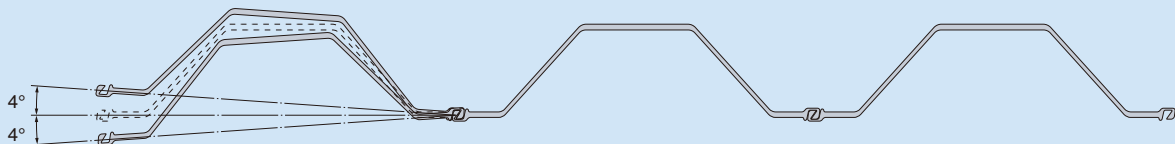

U-shaped Steel Sheet Piles

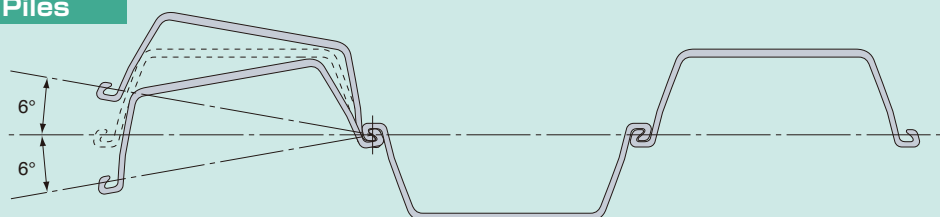

Corner Steel Sheet Piles

Hot-rolled Corner Steel Sheet Piles

These are steel sheet piles exclusively manufactured for 90° corner parts by hot rolling. Since they are hot-rolled products, they have less shape distortion compared to processed corner sheet piles, and are convenient for transport and storage as they can be stacked. They can also be driven in the same way as general steel sheet piles.

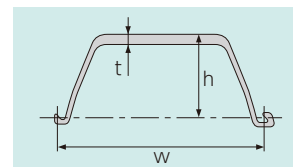

Combination Steel Sheet Piles

Type	Dimensions			Cross section	Weight		Geometrical moment of inertia		Section modulus	
	W (mm)	h (mm)	t (mm)	Per steel sheet pile $\times 10^{-4}$ (m ²)	Per steel sheet pile (kg/m)	Per each meter of wall width (kg/m ²)	Per steel sheet pile $\times 10^{-8}$ (m ⁴)	Per each meter of wall width $\times 10^{-8}$ (m ⁴ /m)	Per steel sheet pile $\times 10^{-6}$ (m ³)	Per each meter of wall width $\times 10^{-6}$ (m ³ /m)
JFESP-C3	400	125	13.0	76.42	60.0	150	2,220	16,800	223	1,340
JFESP-C4	400	170	15.5	96.99	76.1	190	4,670	38,600	362	2,270

1 Material

The same material is used for Hot-rolled corner steel sheet piles as U-shaped steel sheet piles.

2 Standard rotation angle

The standard turning angles when type C3 and type 3 are engaged, as well as when type C4 and type 4 are engaged, are shown to the right.

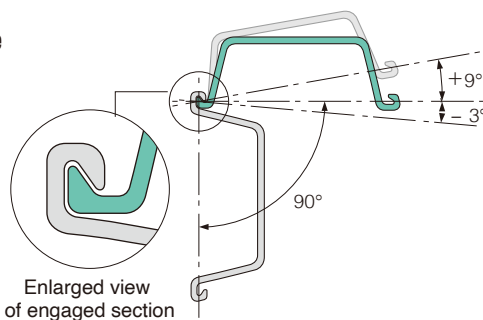

3 Interchangeability

C3/C4 and U-shaped

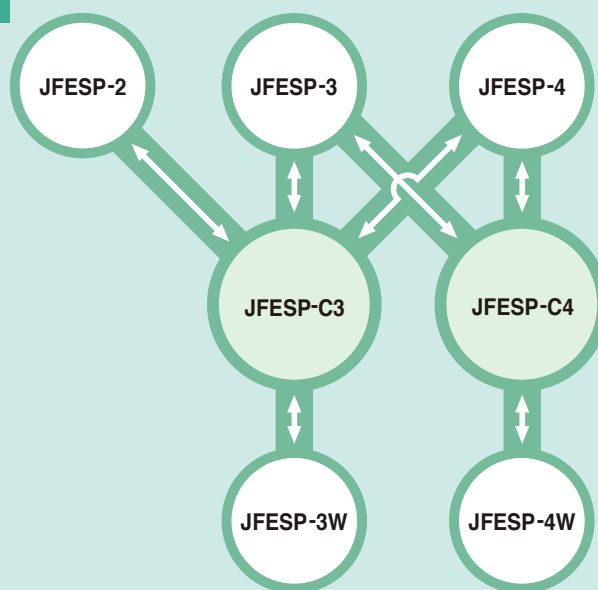

- This shows the compatibility of corner joints.
- While this shows the standard possible engagement range, please note that it may vary depending on the construction conditions.

4 Driving procedure

Wall closing is easy when the central dimension of the steel sheet pile wall is a multiple of the effective width of the steel sheet piles.

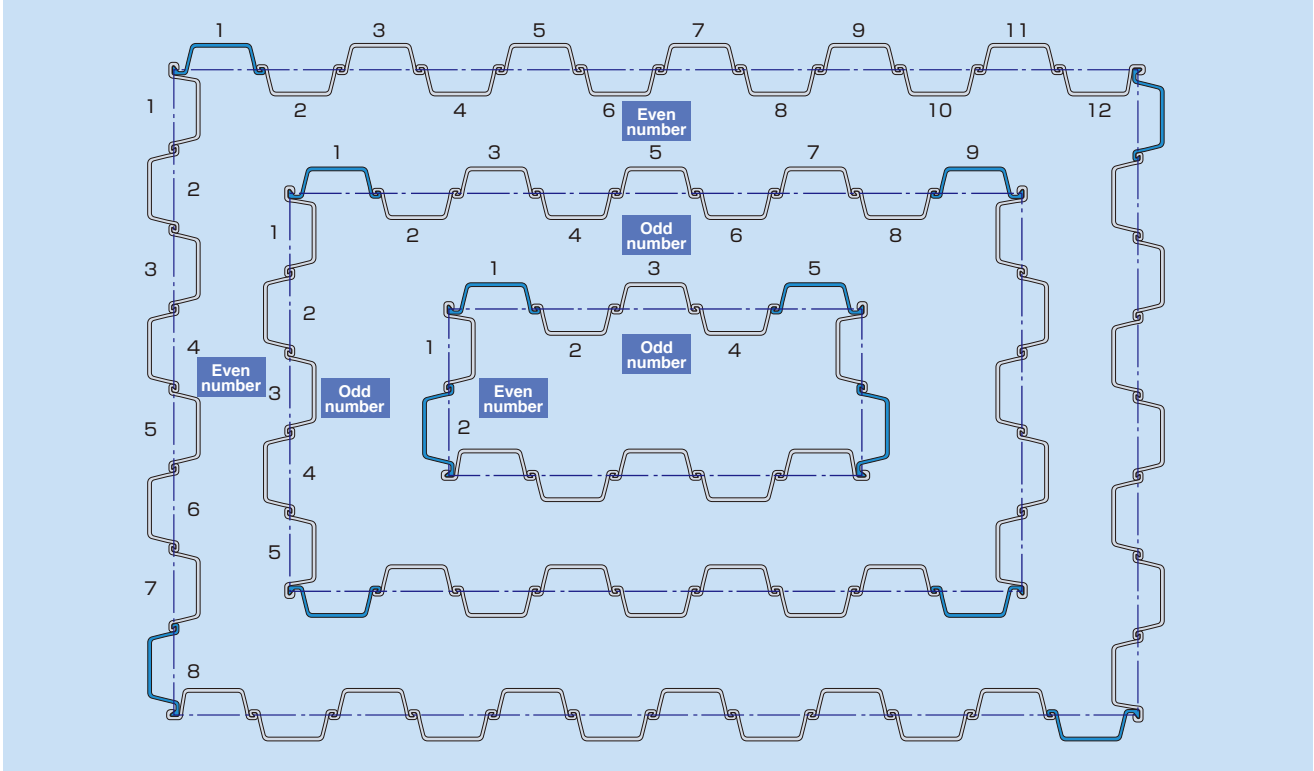

Deformed Steel Sheet Piles

Please inquire individually about whether deformed steel sheet piles can be manufactured.

Hat-shaped Steel Sheet Piles

1. When changing the normal to a right angle

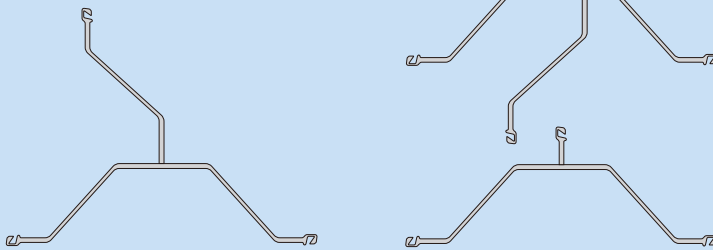

2. When connecting with a U-shaped steel sheet pile

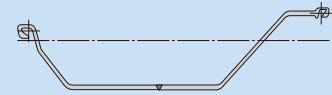

U-shaped Steel Sheet Piles

1. Corner sheet piles

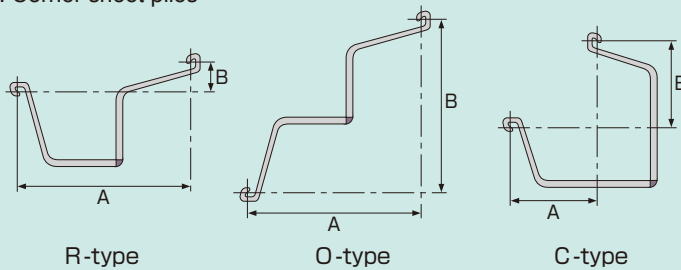

2. Connected sheet piles

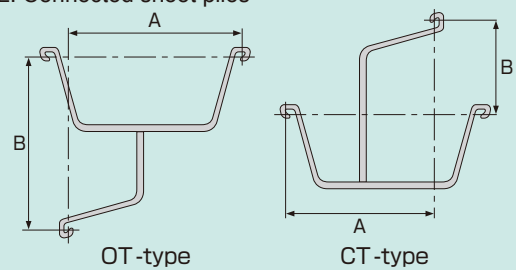

● Deformed steel sheet piles are manufactured based on the dimensions A and B.

Table of Weights

(Unit: kg)

Length m	Type	Hat-shaped Steel Sheet Piles				U-shaped Steel Sheet Piles							
		10H	25H	45H	50H	2W	3W	4W	2	3	4	5L	6L
1.0		86.4	113	147	167	61.8	81.6	106	48.0	60.0	76.1	105	120
5.0		432	565	734	835	309	408	530	240	300	380	525	600
5.5		475	622	807	918	340	449	583	264	330	419	578	660
6.0		518	678	881	1,002	371	490	636	288	360	457	630	720
6.5		562	734	954	1,085	402	530	689	312	390	495	682	780
7.0		605	791	1,028	1,169	433	571	742	336	420	533	735	840
7.5		648	848	1,101	1,252	464	612	795	360	450	571	788	900
8.0		691	904	1,174	1,336	494	653	848	384	480	609	840	960
8.5		734	960	1,248	1,419	525	694	901	408	510	647	892	1,020
9.0		778	1,017	1,321	1,503	556	734	954	432	540	685	945	1,080
9.5		821	1,074	1,395	1,586	587	775	1,007	456	570	723	998	1,140
10.0		864	1,130	1,468	1,670	618	816	1,060	480	600	761	1,050	1,200
10.5		907	1,186	1,541	1,753	649	857	1,113	504	630	799	1,102	1,260
11.0		950	1,243	1,615	1,837	680	898	1,166	528	660	837	1,155	1,320
11.5		994	1,300	1,688	1,920	711	938	1,219	552	690	875	1,208	1,380
12.0		1,037	1,356	1,762	2,004	742	979	1,272	576	720	913	1,260	1,440
12.5		1,080	1,412	1,835	2,087	772	1,020	1,325	600	750	951	1,312	1,500
13.0		1,123	1,469	1,908	2,171	803	1,061	1,378	624	780	989	1,365	1,560
13.5		1,166	1,526	1,982	2,254	834	1,102	1,431	648	810	1,027	1,418	1,620
14.0		1,210	1,582	2,055	2,338	865	1,142	1,484	672	840	1,065	1,470	1,680
14.5		1,253	1,638	2,129	2,421	896	1,183	1,537	696	870	1,103	1,522	1,740
15.0		1,296	1,695	2,202	2,505	927	1,224	1,590	720	900	1,142	1,575	1,800

Please choose the type and length in consideration of design and workability.

JFESP™-Related Products

H-Shaped Steel Piles

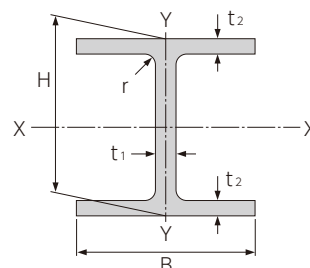

■ Dimensions and cross-section performance values

Nominal size	Dimensions (mm)					Cross section m ²	Unit weight kg/m	Geometrical moment of inertia		Section modulus		Radius of gyration	
	H	B	t ₁	t ₂	r			I _x m ⁴	I _y m ⁴	Z _x m ³	Z _y m ³	i _x m	i _y m
200×200	200	200	8	12	13	6,353 × 10 ⁻⁶	49.9	472 × 10 ⁻⁷	160 × 10 ⁻⁷	472 × 10 ⁻⁶	160 × 10 ⁻⁶	862 × 10 ⁻⁴	502 × 10 ⁻⁴
250×250	250	250	9	14	13	9,143 × 10 ⁻⁶	71.8	107 × 10 ⁻⁶	365 × 10 ⁻⁷	860 × 10 ⁻⁶	292 × 10 ⁻⁶	108 × 10 ⁻³	632 × 10 ⁻⁴
300×300	300	300	10	15	13	1,185 × 10 ⁻⁵	93.0	202 × 10 ⁻⁶	675 × 10 ⁻⁷	135 × 10 ⁻⁵	450 × 10 ⁻⁶	131 × 10 ⁻³	755 × 10 ⁻⁴
350×350	344	348	10	16	13	1,440 × 10 ⁻⁵	113	328 × 10 ⁻⁶	112 × 10 ⁻⁶	191 × 10 ⁻⁵	646 × 10 ⁻⁶	151 × 10 ⁻³	884 × 10 ⁻⁴
	350	350	12	19	13	1,719 × 10 ⁻⁵	135	398 × 10 ⁻⁶	136 × 10 ⁻⁶	228 × 10 ⁻⁵	776 × 10 ⁻⁶	152 × 10 ⁻³	889 × 10 ⁻⁴
400×400	400	400	13	21	22	2,187 × 10 ⁻⁵	172	666 × 10 ⁻⁶	224 × 10 ⁻⁶	333 × 10 ⁻⁵	112 × 10 ⁻⁵	175 × 10 ⁻³	101 × 10 ⁻³
	400	408	21	21	22	2,507 × 10 ⁻⁵	197	709 × 10 ⁻⁶	238 × 10 ⁻⁶	354 × 10 ⁻⁵	117 × 10 ⁻⁵	168 × 10 ⁻³	975 × 10 ⁻⁴
	414	405	18	28	22	2,954 × 10 ⁻⁵	232	928 × 10 ⁻⁶	310 × 10 ⁻⁶	448 × 10 ⁻⁵	153 × 10 ⁻⁵	177 × 10 ⁻³	102 × 10 ⁻³
	428	407	20	35	22	3,607 × 10 ⁻⁵	283	119 × 10 ⁻⁵	394 × 10 ⁻⁶	557 × 10 ⁻⁵	193 × 10 ⁻⁵	182 × 10 ⁻³	104 × 10 ⁻³
	458	417	30	50	22	5,286 × 10 ⁻⁵	415	187 × 10 ⁻⁵	605 × 10 ⁻⁶	817 × 10 ⁻⁵	290 × 10 ⁻⁵	188 × 10 ⁻³	107 × 10 ⁻³
	498	432	45	70	22	7,701 × 10 ⁻⁵	605	298 × 10 ⁻⁵	944 × 10 ⁻⁶	120 × 10 ⁻⁴	437 × 10 ⁻⁵	197 × 10 ⁻³	111 × 10 ⁻³
500×500	500	500	25	25	26	3,683 × 10 ⁻⁵	289	163 × 10 ⁻⁵	522 × 10 ⁻⁶	652 × 10 ⁻⁵	209 × 10 ⁻⁵	210 × 10 ⁻³	119 × 10 ⁻³

Length : Standard length is as per JIS, and maximum length is 30.0 m.

Material: SHK400 and SHK490M in JIS A 5526 H-shaped steel piles for H-shaped steel piles used for the foundation of civil engineering building structures
SS400 in JIS G 3101 rolled steels for general structures is the standard material for H-shaped steel used for general structures.

JFESP™-Related Products

JFE Marine Coat™ Steel Sheet Piles (Heavy-duty Corrosion-proof Steel Sheet Piles)

● Features of JFE Marine Coat™ Steel Sheet Piles

1. Excellent long-term corrosion-proof properties

JFE Marine Coat™ steel sheet piles use urethane elastomer, which has excellent chemical and weather resistance, as the coating material, and has long-term corrosion-proof performance and durability. ^{*1)}

2. Excellent economic efficiency

JFE Marine Coat™ steel sheet piles can be expected to provide long-term corrosion-proof performance, thereby reducing the total cost of structural corrosion protection.

3. Superior quality

Manufactured in a factory under strict quality control, it is a uniform and high-quality product. ^{*2)}

※1) Heavy-duty corrosion-proof steel sheet piles require regular maintenance after installation. For details, please refer to the "Guidelines for Corrosion Prevention and Repair of Port and Harbour Steel Structures" and "Guidelines for Maintenance and Repair of Port and Harbour Steel Structures" issued by the Coastal Development Institute of Technology.

※2) Heavy-duty corrosion-proof steel sheet piles are manufactured for use in general ports and harbors.

● Structure of coating

Urethane elastomer coating

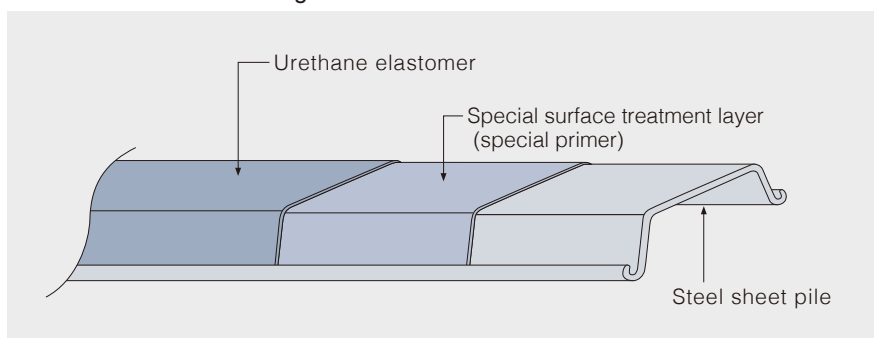

● Basic properties of JFE Marine Coat™ coating material

The basic properties of the coating material (urethane elastomer) used for JFE Marine Coat™ steel sheet piles are listed below.

Urethane elastomer coating

Item	Numeric value ^{*3)}
Specific gravity (g/cm ³)	1.0 min.
Tensile strength (MPa)	8.0 min.
Tensile fracture strain (%)	30 min.
Hardness (HDD)	50 min.
Water absorption rate (%)	0.35 max.
Volume resistivity (Ω · cm)	1.0×10 ¹² min.
Adhesive strength (MPa)	3.0 min.

*3) According to the "Specifications for Heavy-duty Corrosion-proof Steel Sheet Pile Products," published by Japanese Technical Association for Steel Pipe Piles and Sheet Piles.

● Range and specifications of manufacture

Type of steel sheet pile	Coated length (m) ^{*1}		Uncoated length at ends(mm)	Coating thickness (mm)	Color
2W, 3W, 4W, 5L, 6L	Urethane elastomer	1~6	300min.	Standard 2.0	Black
10H,25H,45H,50H					

*1) Please contact us for information on coating lengths of 6 to 9 m.



● While heavy-duty corrosion-proof coating is possible even for complex shapes including deformed steel sheet piles, please contact us for information on the specifications.

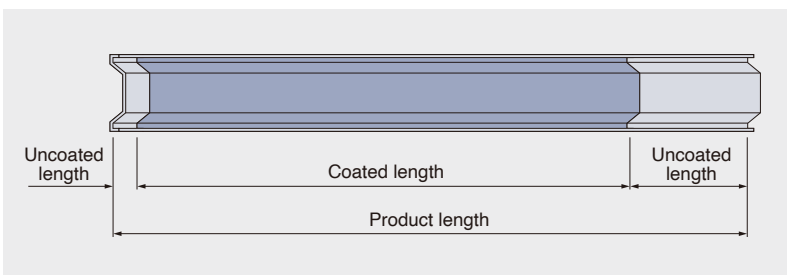

Coated length per section (reference value) (Unit: m)

Section	Coated length (m)
10H	1.05
25H	1.20
45H	1.32
50H	1.33
2W	0.65
3W	0.72
4W	0.75
5L	0.66
6L	0.70
2W	0.77
3W	0.84
4W	0.87
5L	0.76
6L	0.80

● Coating range on joints

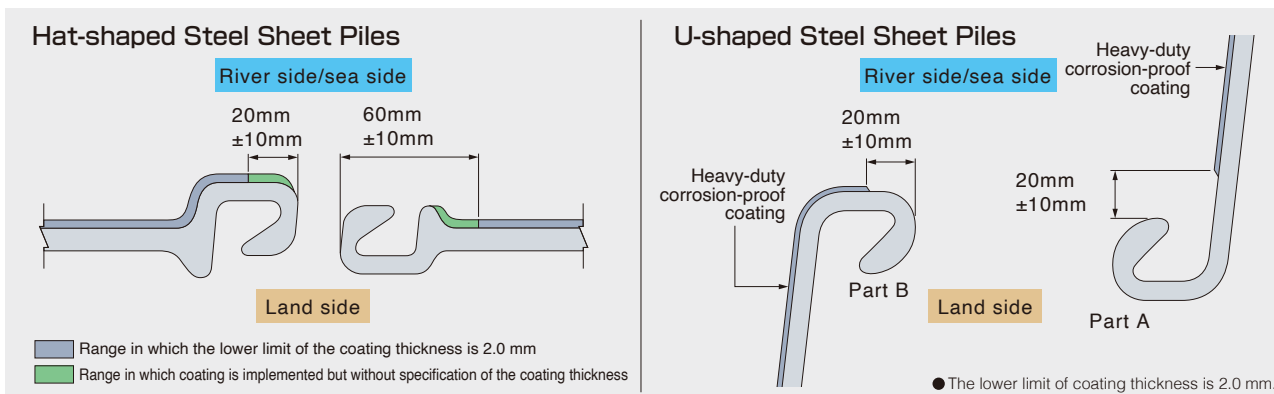

Section Modulus of Steel Sheet Piles after Corrosion

Calculations of the section modulus of steel sheet piles after corrosion are shown below.

Hat-shaped Steel Sheet Piles

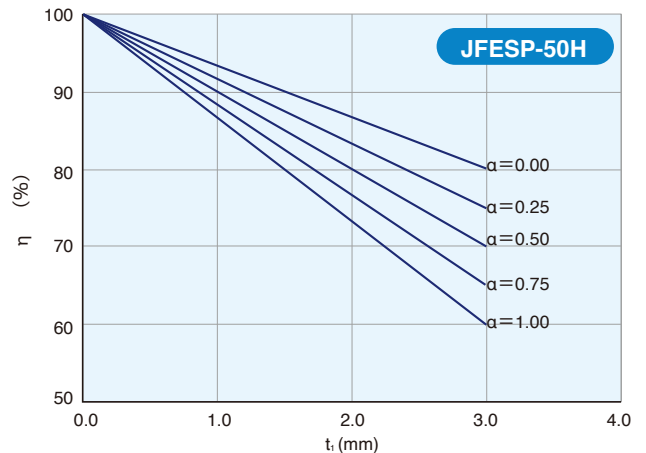
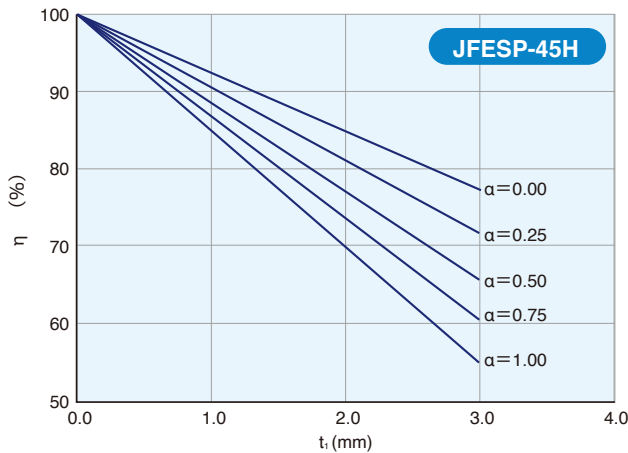
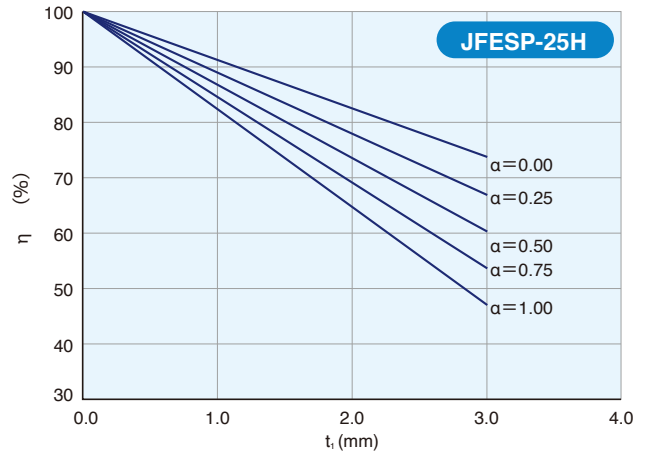
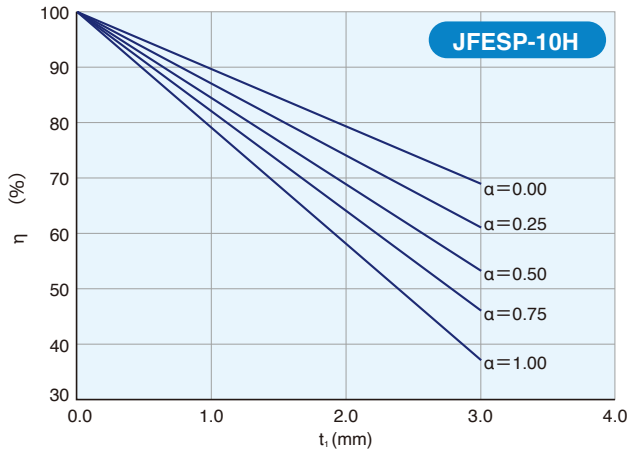

Z : Section modulus of steel sheet pile after corrosion ($\times 10^{-6} \text{ m}^3/\text{m}$)
 Z_0 : Section modulus of steel sheet pile without corrosion ($\times 10^{-6} \text{ m}^3/\text{m}$)
 η : Ratio of section modulus of steel sheet pile after corrosion to Z_0 : $\eta = Z/Z_0$ (%)
 t_1, t_2 : Thickness of corrosion on respective sides of steel sheet pile (mm)
 α : Ratio of t_2 to t_1 : $\alpha = t_2/t_1$

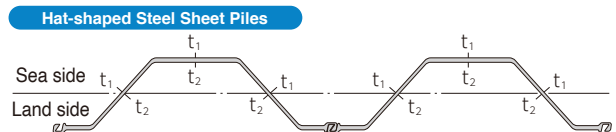

● For details, please refer to "Steel Sheet Piles - From Design to Construction" -, published by Japanese Technical Association for Steel Pipe Piles and Sheet Piles.

U-shaped Steel Sheet Piles

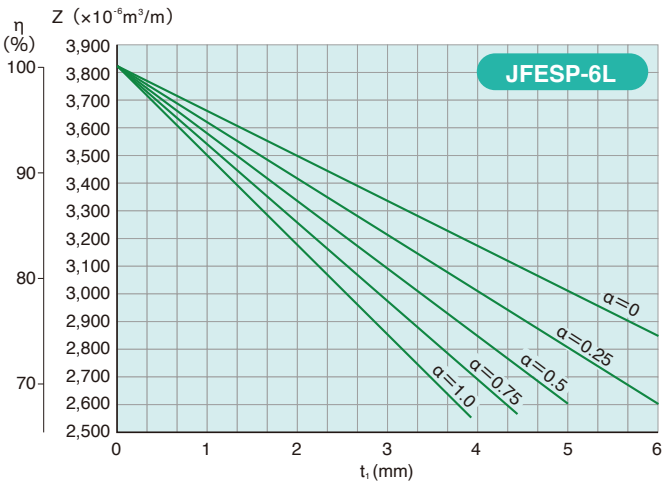
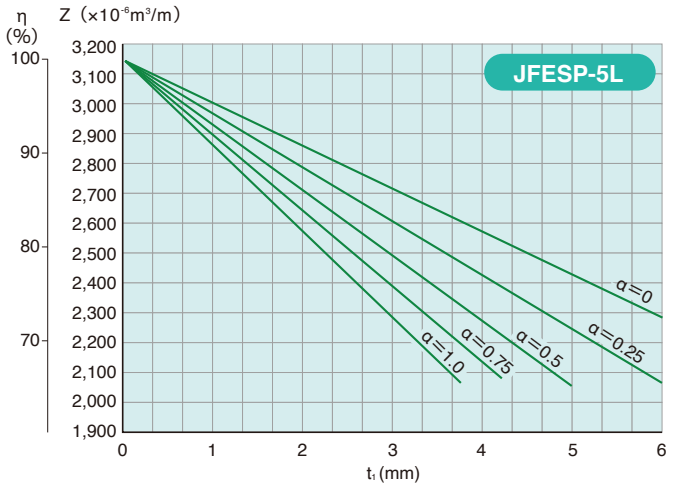
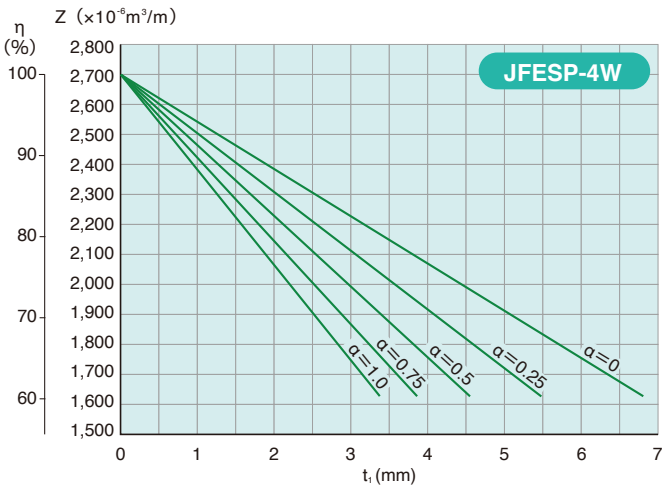
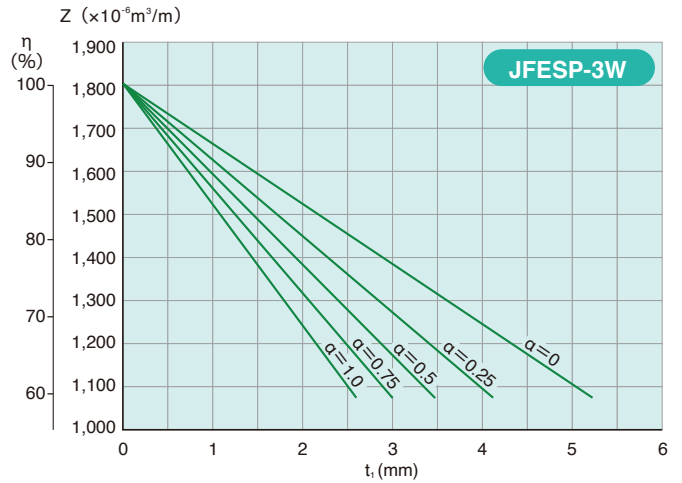
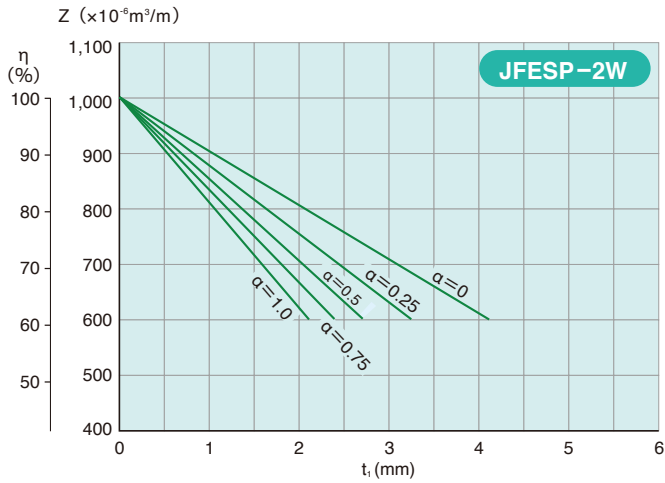

Z : Section modulus of steel sheet pile after corrosion ($\times 10^{-6} \text{m}^3/\text{m}$)
 Z_0 : Section modulus of steel sheet pile without corrosion ($\times 10^{-6} \text{m}^3/\text{m}$)
 η : Ratio of section modulus of steel sheet pile after corrosion to Z_0 : $\eta = Z/Z_0$ (%)
 t_1, t_2 : Thickness of corrosion on respective sides of steel sheet pile (mm)
 α : Ratio of t_2 to t_1 : $\alpha = t_2/t_1$

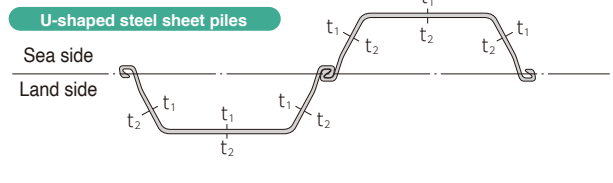

● For details, please refer to "Steel Sheet Piles - From Design to Construction" -, published by Japanese Technical Association for Steel Pipe Piles and Sheet Piles.

Construction Methods

The major construction methods for steel sheet piles are the press-in method and the vibratory hammer method. Appropriate construction methods and machines are selected according to the type of steel sheet pile and site conditions.

Press-in method

This is a method that grasps the steel sheet pile that has already been driven in and uses its pull-out resistance force as a reaction force to drive a new steel sheet pile in under hydraulic pressure.

Features

- Capable of construction with low vibration and noise.
- Compact and compatible with constructions in narrow space as well as height restriction.
- Construction can be carried out even on hard ground using an auxiliary method.

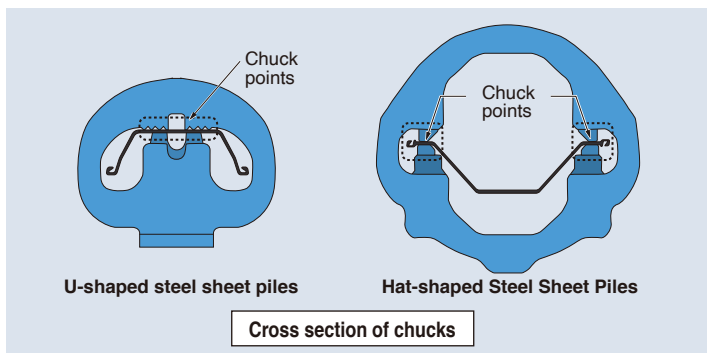

*For details, please contact us beforehand.



Driving scene

Vibratory hammer method

This is a method that drives the steel sheet pile into the ground by transmitting the vertical vibration generated by the vibratory hammer to the steel sheet pile.

Features

- There is no damage to the head of the steel sheet pile because the striking force is not used.
- High construction efficiency.
- It can be used for both driving and pulling.

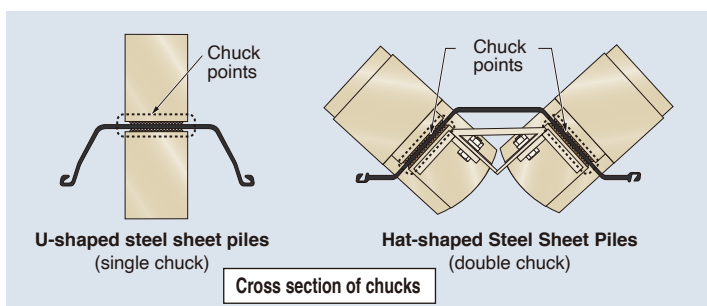

【Note】 For Hat-shaped steel sheet Piles

- *Using the double chuck is recommended to stabilize pile driving.
- *For details, please contact us beforehand.

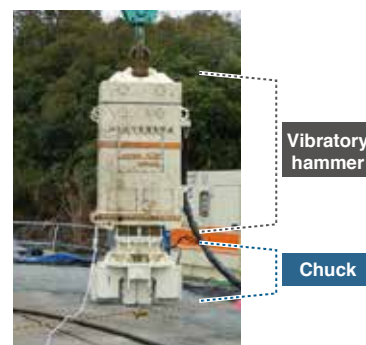

Example of double chuck mounting



Driving scene

Examples of Labeling

Examples of labeling

① JFE WK		⑦ ●	⑧	⑨
SPEC 規格				
② SYW295				
SIZE 断面寸法				
③ JFESP-3W				
HEAT No. 炉号番		LENGTH 長さ		
⑥ 3-62250	④ 9.5 M		③	
LOT No. ロットNo.		PRODUCT No. 製品No.		
A276	8CLR056-01	P		
⑤ F8602-700		E4ARS-C		
				F8602-700

⑦ ●	② SYW295	① JFE
③	③ JFESP-2	
④ 12.00 M	⑥ C-5408 Q2	
	WD56235-002	
30/9A	⑤ 8A1211-001A	
JFE-WF		
		

- ① Company mark
- ② Standard code
- ③ Type of sheet pile
- ④ Length
- ⑤ Product No.
- ⑥ Steel No.
- ⑦ JIS mark
- ⑧ Abbreviation of accredited certification body
- ⑨ Certification No.

JFE Steel Corporation<https://www.jfe-steel.co.jp/en/>**HEAD OFFICE**

Hibiya Kokusai Building, 2-3 Uchisaiwaicho 2-chome, Chiyodaku, Tokyo 100-0011, Japan Phone: (81)3-3597-3111 Fax: (81)3-3597-4860

ASIA PACIFIC**SEOUL**JFE Steel Korea Corporation
16th Floor, 41, Cheonggyecheon-ro, Jongno-gu, Seoul,
03188, Korea
(Youngpung Building, Seorin-dong)
Phone: (82)2-399-6337 Fax: (82)2-399-6347**SHANGHAI**JFE Consulting (Shanghai) Co., Ltd.
Room 801, Building A, Far East International Plaza,
319 Xianxia Road, Shanghai 200051, P.R.China
Phone: (86)21-6235-1345 Fax: (86)21-6235-1346**BEIJING**JFE Consulting (Shanghai) Co., Ltd. Beijing Branch
821 Beijing Fortune Building No.5 Dongsanhuan
North Road, Chaoyang District, Beijing, 100004,
P.R.China
Phone: (86)10-6590-9051**GUANGZHOU**JFE Consulting (Guangzhou) Co., Ltd.
Room 3901 Citic Plaza, 233 Tian He North Road,
Guangzhou, 510613, P.R.China
Phone: (86)20-3891-2467 Fax: (86)20-3891-2469**MANILA**JFE Steel Corporation, Manila Office
23rd Floor 6788 Ayala Avenue, Oledan Square,
Makati City, Metro Manila, Philippines
Phone: (63)2-8886-7432 Fax: (63)2-8886-7315**HO CHI MINH CITY**JFE Steel Vietnam Co., Ltd.
Unit 1704, 17th Floor, MPLaza, 39 Le Duan Street,
Dist 1, HCMC, Vietnam
Phone: (84)28-3825-8576 Fax: (84)28-3825-8562**HANOI**JFE Steel Vietnam Co., Ltd., Hanoi Branch
Unit 1501, 15th Floor, Cornerstone Building, 16 Phan
Chu Trinh Street, Hoan Kiem Dist., Hanoi, Vietnam
Phone: (84)24-3855-2266 Fax: (84)24-3533-1166**BANGKOK**JFE Steel (Thailand) Ltd.
22nd Floor, Abdulrahim Place 990, Rama IV Road,
Silom, Bangrak, Bangkok 10500, Thailand
Phone: (66)2-636-1886 Fax: (66)2-636-1891**YANGON**JFE Steel (Thailand) Ltd., Yangon Office
Unit 05-01, Union Business Center, Nat Mauk Road,
Bocho Quarter, Bahan Tsp, Yangon, 11201, Myanmar
Phone: (95)1-860-3352**SINGAPORE**JFE Steel Asia Pte. Ltd.
16 Raffles Quay, No.15-03, Hong Leong Building,
048581, Singapore
Phone: (65)6220-1174 Fax: (65)6224-8357**JAKARTA**PT. JFE STEEL INDONESIA
6th Floor Summitmas II, JL Jendral Sudirman Kav.
61-62, Jakarta 12190, Indonesia
Phone: (62)21-522-6405 Fax: (62)21-522-6408**NEW DELHI**JFE Steel India Private Limited
806, 8th Floor, Tower-B, Unitech Signature Towers,
South City-I, NH-8, Gurgaon-122001, Haryana, India
Phone: (91)124-426-4981 Fax: (91)124-426-4982**MUMBAI**JFE Steel India Private Limited, Mumbai Office
603-604, A Wing, 215 Atrium Building, Andheri-Kurla
Road, Andheri (East), Mumbai-400093, Maharashtra,
India
Phone: (91)22-3076-2760 Fax: (91)22-3076-2764**BRISBANE**JFE Steel Australia Resources Pty Ltd.
Level28, 12 Creek Street, Brisbane QLD 4000
Australia
Phone: (61)7-3229-3855 Fax: (61)7-3229-4377**MIDDLE EAST****DUBAI**JFE Steel Corporation, Dubai Office
P.O.Box 261791 LOB19-1208, Jebel Ali Free Zone
Dubai, U.A.E.
Phone: (971)4-884-1833 Fax: (971)4-884-1472**NORTH, CENTRAL and SOUTH AMERICA****HOUSTON**JFE Steel America, Inc.
750 Town & Country Blvd., Suite 705, Houston,
TX 77024, U.S.A.
Phone: (1)713-532-0052 Fax: (1)713-532-0062**MEXICO CITY**JFE Steel de Mexico S.A. de C.V.
Ruben Dario #281-1002, Col. Bosque de
Chapultepec, C.P. 11580, CDMX. D.F. Mexico
Phone: (52)55-5985-0097**RIO DE JANEIRO**JFE Steel do Brasil LTDA
Praia de Botafogo, 228 Setor B, Salas 508 & 509,
Botafogo, CEP 22250-040, Rio de Janeiro-RJ, Brazil
Phone: (55)21-2553-1132 Fax: (55)21-2553-3430**Notice**

While every effort has been made to ensure the accuracy of the information contained within this publication, the use of the information is at the reader's risk and no warranty is implied or expressed by JFE Steel Corporation with respect to the use of information contained herein. The information in this publication is subject to change or modification without notice. Please contact the JFE Steel office for the latest information.